

RK30880E

Water-in-Fuel Detection Kit

Instruction Part Number 22557 Rev B



Overview:

This kit includes new and enhanced detection electronics built into the probe body and works with 12 or 24 volt DC systems.

Once the level of collected water rises to make contact between the two probe tips, a yellow warning light will illuminate, indicating time to drain water and contaminants from the collection bowl.

Follow draining instructions provided with each fuel filter/water separator to drain the collection bowl. After water has been drained, the warning light will reset and no longer be illuminated.

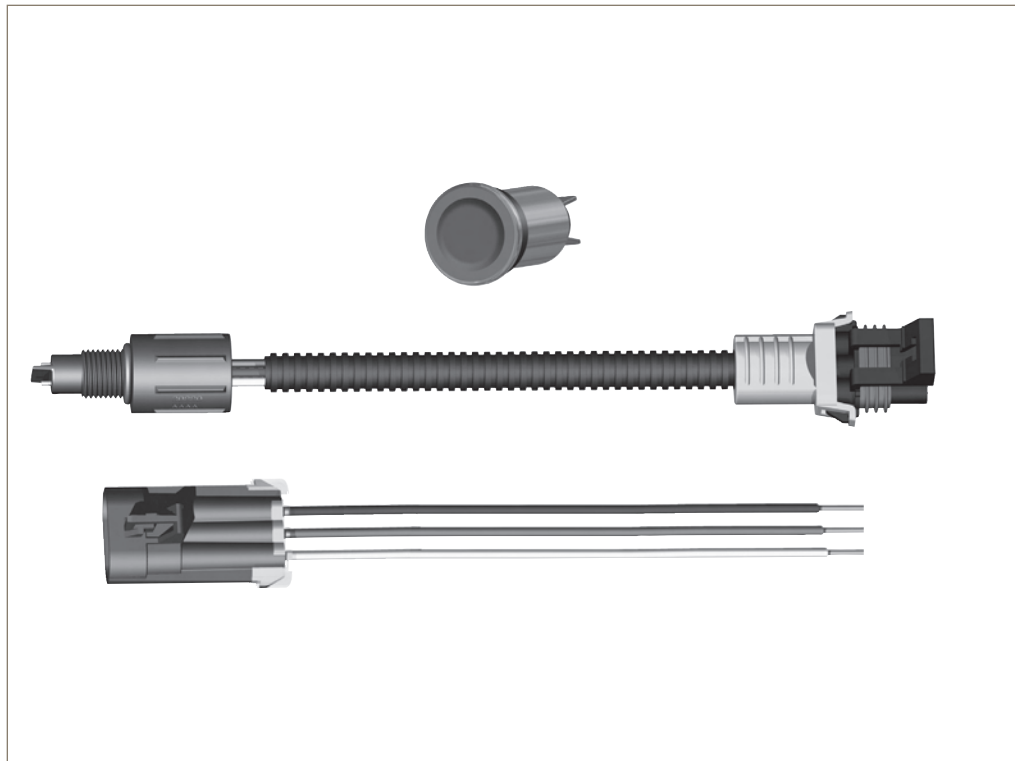

Contact Information: Product Features:

Parker Hannifin Corporation

Racor Division

P.O. Box 3208

3400 Finch Road

Modesto, CA 95353

phone 800 344 3286

209 521 7860

fax 209 529 3278

racor@parker.com

www.parker.com/racor

www.parker.com/racorproducts

- Housing Permanently Marked for Identification
- Includes a Warning Light
- Circuit Board Power Controller (10 volt continuous)
- Reverse Polarity Protection
- Built-in Amplifier
- False Detection Prevention (water slosh delay)
- Electromagnetic Compatibility (EMC)



ENGINEERING YOUR SUCCESS.

RK30880E

Specifications

<i>Port Thread Size</i>	1/2"-20 UNF
<i>Housing</i>	Nylon
<i>Volts DC</i>	12 or 24
<i>ohm</i>	47K
<i>Ambient Fuel Temperature</i>	-40° to +250°F (-40° to +121°C)
<i>Maximum Fuel Temp</i>	190°F (88°C)

The RK30880E is for diesel applications only. Do not use in gasoline applications.

Installation Guidelines

Disconnect the positive terminal from the battery to avoid the potential hazard of electrical shock. Run the wires in protected locations and avoid hot surfaces and places that could pinch or rub on wires.

1. Lubricate o-ring on water probe with clean motor oil, then install into collection bowl. Tighten probe body snugly by hand only.
2. Connect **BLACK** wire on connector assembly to ground, **RED** wire to +12/24 vdc, and **YELLOW** wire to either side of supplied lamp (use a supplied spade connector).
3. Use loose black wire (supplied with lamp) and spade connector to connect other side of lamp to 1 amp fuse +12/24 vdc.
4. Use cable ties to secure any loose wires. Reconnect positive battery terminal.

Installation Information

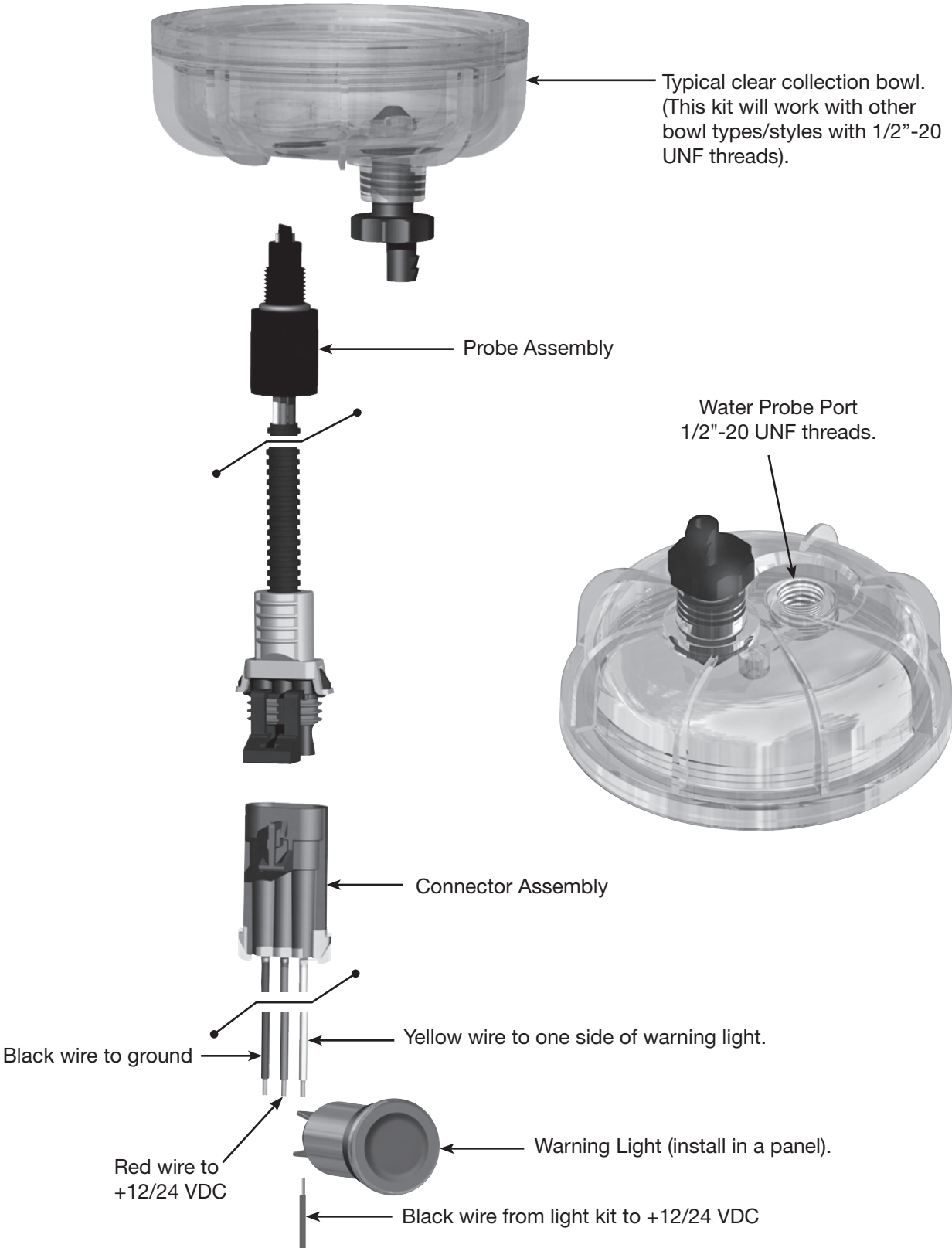

Limited Warranties Statement

All products manufactured or distributed by Racor are subject to the following, and only the following, LIMITED EXPRESS WARRANTIES, and no others: For a period of one (1) year from and after the date of purchase of a new Racor product, Racor warrants and guarantees only to the original purchaser-user that such a product shall be free from defects of materials and workmanship in the manufacturing process. The warranty period for pumps and motors is specifically limited to ninety (90) days from date of purchase. A product claimed to be defective must be returned to the place of purchase. Racor, at its sole option, shall replace the defective product with a comparable new product or repair the defective product. This express warranty shall be inapplicable to any product not properly installed and properly used by the purchaser-user or to any product damaged or impaired by external forces.

THIS IS THE EXTENT OF WARRANTIES AVAILABLE ON THIS PRODUCT. RACOR SHALL HAVE NO LIABILITY WHATSOEVER FOR CONSEQUENTIAL DAMAGES

FLOWING FROM THE USE OF ANY DEFECTIVE PRODUCT OR BY REASON OF THE FAILURE OF ANY PRODUCT. RACOR SPECIFICALLY DISAVOWS ALL OTHER WARRANTIES, EXPRESS OR IMPLIED INCLUDING, WITHOUT LIMITATION, ALL WARRANTIES OF FITNESS FOR A PARTICULAR PURPOSE (EXCEPT FOR THOSE WHICH APPLY TO PRODUCT OR PART THEREOF THAT IS USED OR BOUGHT FOR USE PRIMARILY FOR PERSONAL, FAMILY, OR HOUSEHOLD PURPOSES), WARRANTIES OF DESCRIPTION, WARRANTIES OF MERCHANTABILITY, TRADE USAGE OR WARRANTIES OR TRADE USAGE.

Warning

Failure or improper selection or improper use of the products and/or systems described herein or related items can cause death, personal injury and property damage. This document and other information from Parker Hannifin Corporation, its subsidiaries and authorized distributors provide product

and/or system options for further investigation by users having technical expertise. It is important that you analyze all aspects of your application and review the information concerning the product or system in the current product catalog. Due to the variety of operating conditions and applications for these products or systems, the user, through its own analysis and testing, is solely responsible for making the final selection of the products and systems and assuring that all performance, safety and warning requirements of the applications are met. The products described herein, including with limitation, product features, specifications, designs, availability and pricing, are subject to change by Parker Hannifin Corporation and its subsidiaries at any time without notice.

The following statement is required pursuant to proposition 65, applicable in the State of California: 'This product may contain a chemical known to the State of California to cause cancer or reproductive toxicity'